

Model # 1057 - Designer Letter Opener Model # 1016 - Designer Magnifier Instructions

Kit Features:

- Heavy 24kt gold plating with epoxy coating
- Designed to match other PSI Mont Blanc® Style Pens
- Overall length: Letter opener = 7-1/8"
Magnifier = 6- 11/16"

Required Accessories:

- 7mm, long mandrel
- 7mm drill bit #1555
- Designer bushings #1126
- 7mm barrel trimmer (optional)
- 2-part epoxy glue or insta-cure (cyanoacrylate)

Diagram A / Parts Layout

Handle:

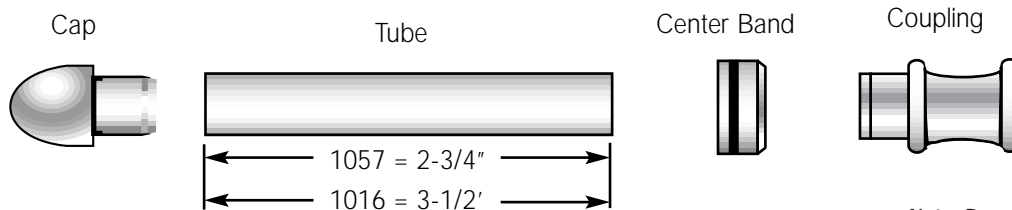

Note: Drawings not to scale

Blade:

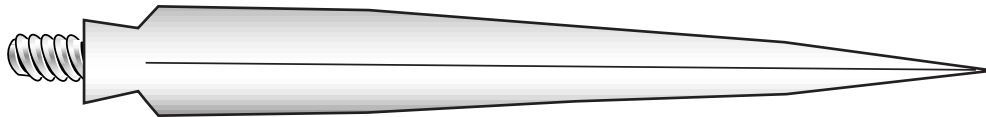

Bushings:

#PKMONT-BU

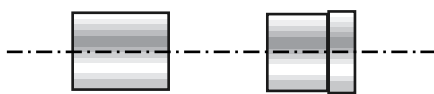

Use These



Do Not Use

Magnifier:

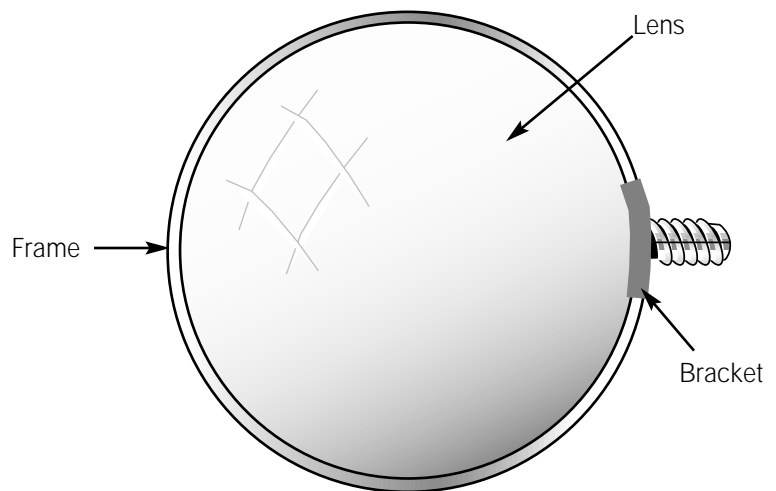

Preparing the Blank:

- Cut 5/8" square blanks, to the length of the brass tubes (add 1/16" for squaring off).
- Drill 7mm centered hole lengthwise through the blank.
- Spread glue over the tube. Insert into the blank with a twisting motion to spread the glue evenly inside.
- Center tube lengthwise inside the blank.
- When glue dries, square the ends of the blank. Use an 7mm barrel trimmer or belt/disc sander. Take wood down flush to the brass tube.

Diagram B / Turning the Wood Blank

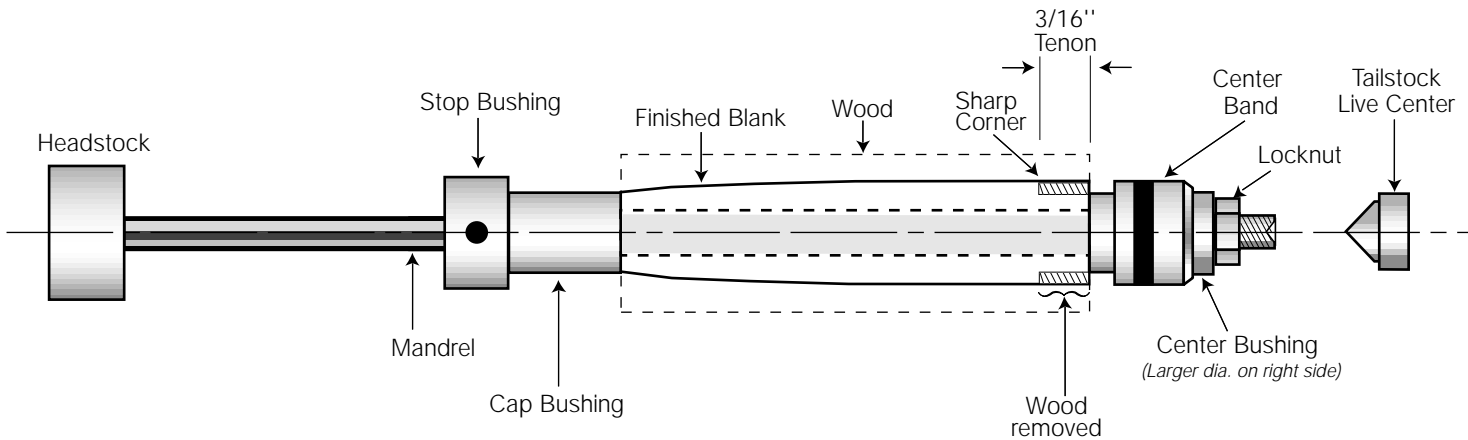

Turning the Blank:

- Place the stop bushing onto the mandrel. Place the cap bushing (wide one) next on the mandrel, then slide on the blank. Place the center band or a scrap band over the center bushing, (square end of band toward cap). Place on mandrel. Use tape to hold the center band away from the blank. Thread the lock nut hand tight. Bring the tailstock snug with the mandrel. (Do not over tighten, it could damage the mandrel). Tighten the stop bushing and lock nut.
- Turn wood down to the bushing and the outside diameter of the center band with chisels and sand paper. Taper the end (follow diagram B for profile) to conform with the cap. Remove tape and use the outside diameter of the band to determine the outside diameter of the blank at that end.

Cutting the Tenon:

- Keep the center band away from the upper blank. Make a pencil mark 3/16" from end. Use a parting tool to cut a 3/16" tenon down to the diameter of the bushing. (Do not cut tenon wider the 3/16"). Use the center band to test for a good fit over the tenon. Make sure you keep a sharp outside 90° corner on the tenon. Finish, varnish and wax both blanks.

Tips:

- Line up finished parts according to the diagram.
- To press parts together, use a vice or a clamping instrument with wooden jaws. Press with caution, to avoid scratching gold plated parts.

Assembly:

- Press cap (recessed end first) into the tapered end of the blank.
- Use a drop of glue around tenon, slide center band (square side first) over tenon. Press in, let dry.
- Press the coupling into the blank flush against the center band.
- Screw on the letter opener blade.

Or

- Screw on the magnifier lens and frame.