

Model #1058

Model #1062

Executive Twist Pen and Pencil Kits

Kit Features:

- Heavy 24 kt. Gold Plated with Epoxy Coating.
- Designed Matching Pen and Pencil Set
- Pen Features Twist Mechanism w/Parker® Type Ball Point Refill.
- Pencil Features Twist Mechanism w/Heavy .7 mm Lead.
- Overall Pen & Pencil Length: 5-1/8".

Required Accessories:

- 7mm Long Mandrel.
- 2 Pc. Pen Bushing Set #1124
- 3/8" Drill Bit: #1582
- 8mm Barrel Trimmer
- 2 Part Epoxy Glue or Insta-Cure (cyanoacrylate).

Preparing The Blank

- Cut 3/4" to 5/8" square the blank (or use PSI jumbo pen blanks) to the length of the brass tube (add 1/16" for squaring off).
- Drill an 3/8" diameter center hole, lengthwise through the blank.
- Spread glue over the tube. Insert the tube into the blank with a twisting motion to spread the glue evenly inside. Center the tube lengthwise inside the blank.
- When the glue dries, square the ends of the blank. Use an 8mm barrel trimmer or a belt/disc sander to trim the wood down flush to the end of the brass tube.

Diagram A - Turning The Blank

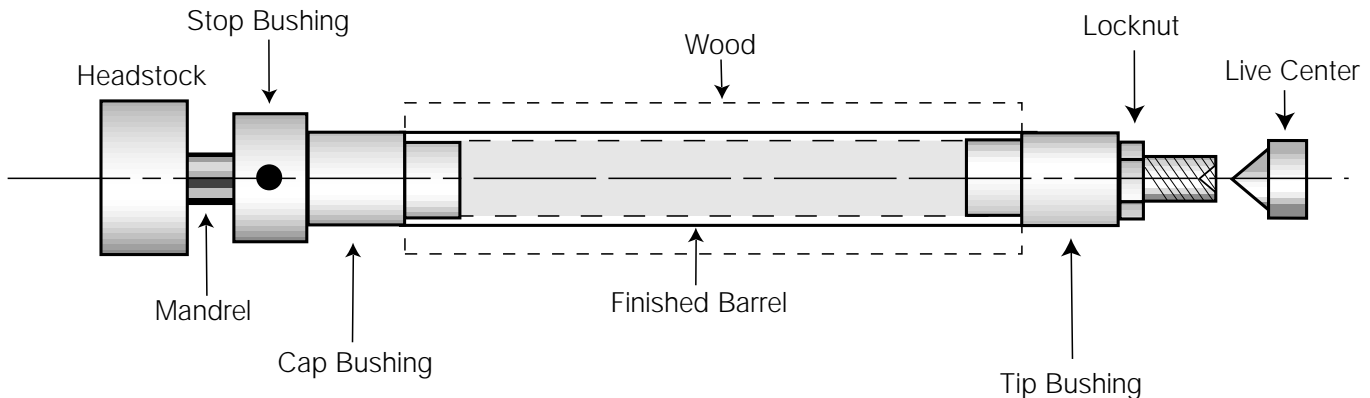

Turning The Blank (Refer to Diagram A)

- Place the stop bushing onto the mandrel hand tight. Next, place one of the bushings (wide dia. first) on the mandrel. Slide on the blank, then place the other bushing (narrow dia. first) on the mandrel. Thread on the lock nut hand tight. Bring the tail stock snug with the mandrel (Do not overtighten, it could damage the mandrel). Slide the stop bushing toward the blank, adjusting to remove spaces. Then tighten the set screw, and tighten the lock nut.
- Using a lathe chisel, turn the blank down flush with the bushings. Finish the blank with gradual higher grits of sand paper and your choice of polish and waxes.

Pen Assembly

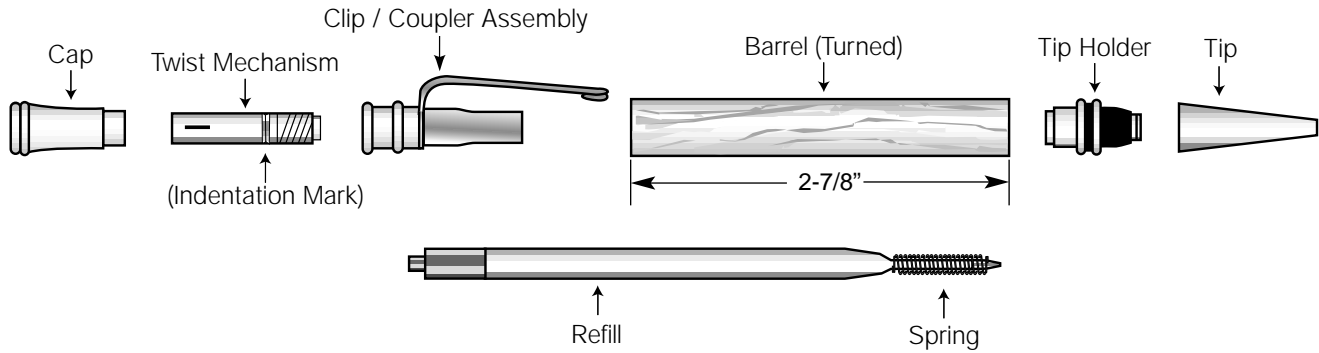

Pen Assembly

- Line up finished parts according to the Diagram above.
- Press the twist mechanism, chrome end first into the cap to the end.
- Press clip/coupler assembly into the barrel.
- Press the tip holder into the tip, to make the tip assembly.
- Press the tip assembly carefully into the other end of the barrel.
- Inert the refill with spring into the barrell
- Screw cap assembly into coupler until it bottoms.
- Pen operates by twisting the cap to extend or retract the refill.

Pencil Assembly

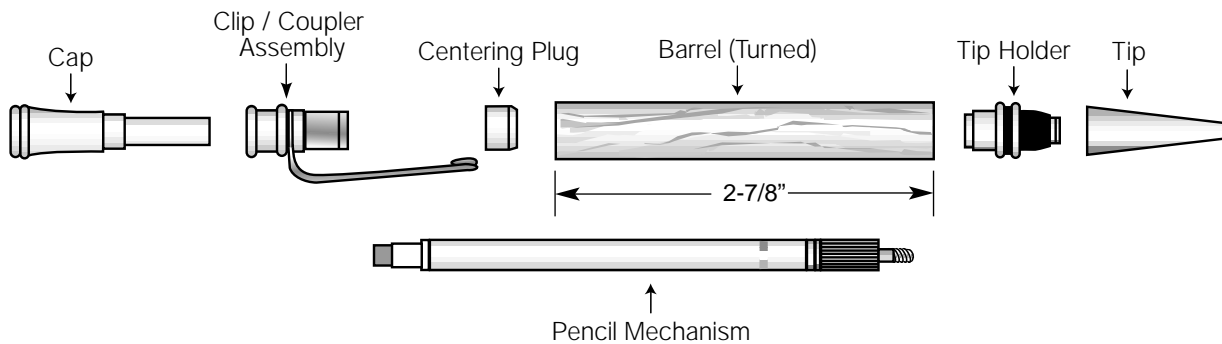

Pen Assembly

- Line up finished parts according to the Diagram above.
- Insert centering plug, recess end first into barrel. Push inside slightly below the surface.
- Press clip/coupler into clip to form assembly.
- Press clip/coupler assembly in front of the centering plug into the barrel, pushing the centering plug inside the barrel.
- Press the tip holder into the the other end of the barrel.
- Insert the pencil mechanism into the barrel with the threaded stud extending through the hole near the tip.
- Thread the tip tightly over exposed thread.

- Insert cap into the clip/coupler. Pushing the centering plug deeper into the barrel.
- Turn the cap to extend or detract the lead as needed.

To Replace The Lead

Unscrew the tip end and pull the pencil mechanism out. Remove the cap. Pull out the eraser and holder together. Remove a new lead from the cartridge and replace the eraser and holder. Twist the mechanism forward until the gripper and pilot extend out. Retract until gripper is flush with the thread. Gently push the new lead into the gripper opening. Twist the mechanism back until the lead is completely inside. Slide the mechanism back tightly. Place the cap over the top. The pencil is again ready to operate.

Bushings - #1124

