

Model #1072 - "Classic" Letter Opener

Model #1073 "Classic" Magnifier

Instructions

Kit Features:

- Heavy 24kt gold plating with epoxy coating
- Designed to match other "Classic" Style Products
- Overall length: Letter Opener = 6-15/16"
Magnifier = 6-3/4"

Required Accessories:

- 7mm, long mandrel
- 8mm drill bit
- Bushings #1134 (Use 2 of the 3 pc. set)
- 8mm barrel trimmer (optional)
- 2-part epoxy glue or insta-cure (cyanoacrylate)

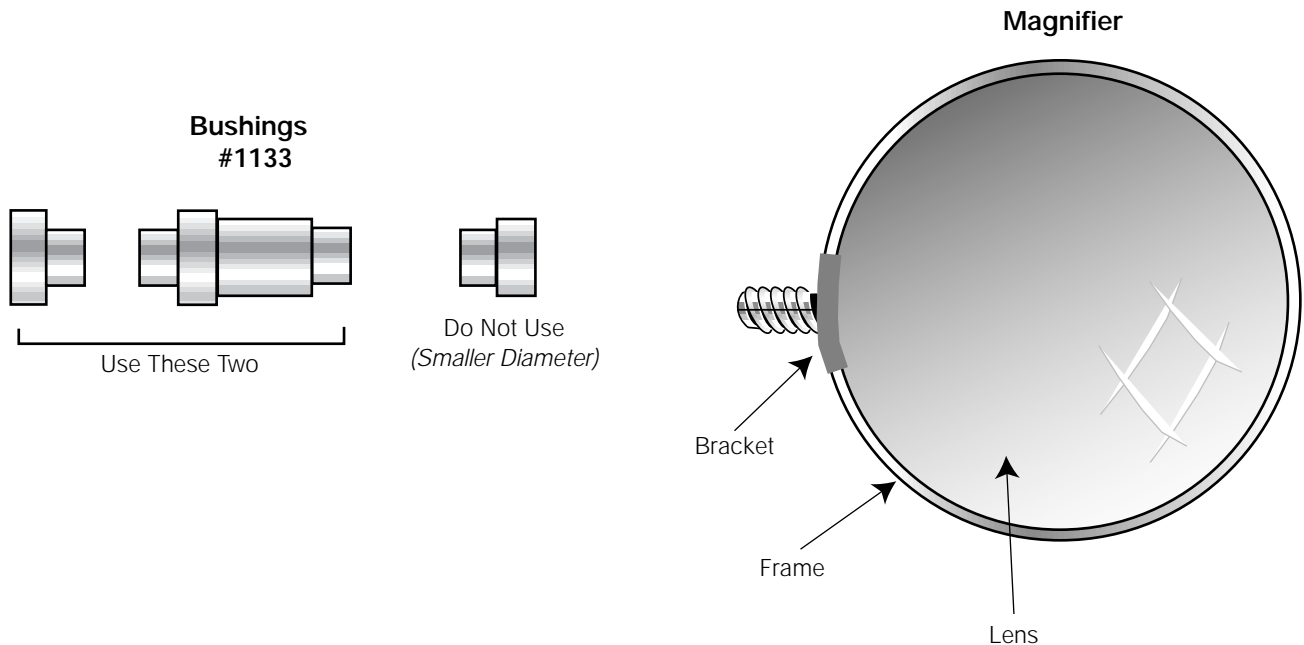
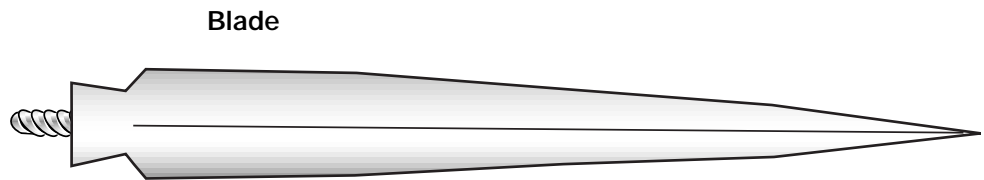
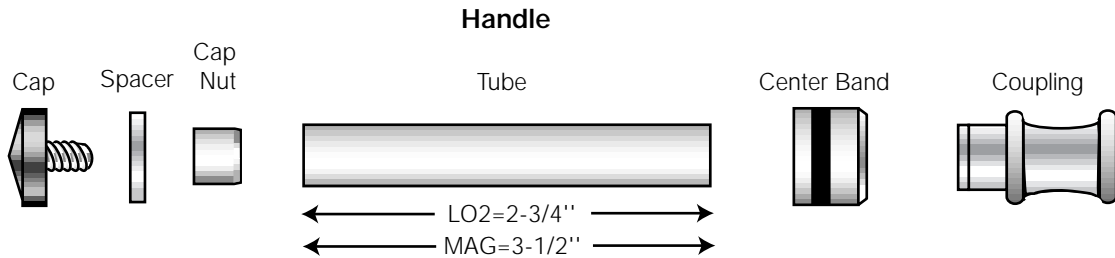

Preparing the Blank:

- Cut 5/8" square blanks, to the length of the brass tube (add 1/16" for squaring off).
- Drill an 8mm centered hole lengthwise through the blank.
- Spread glue over the tube. Insert into the blank with a twisting motion to spread the glue evenly inside.
- Center the tube lengthwise inside the blank.
- When the glue dries, square the ends of the blank. Use an 8mm barrel trimmer or belt/disc sander. Take wood down flush to the brass tube.

Diagram B / Turning the Wood Blank

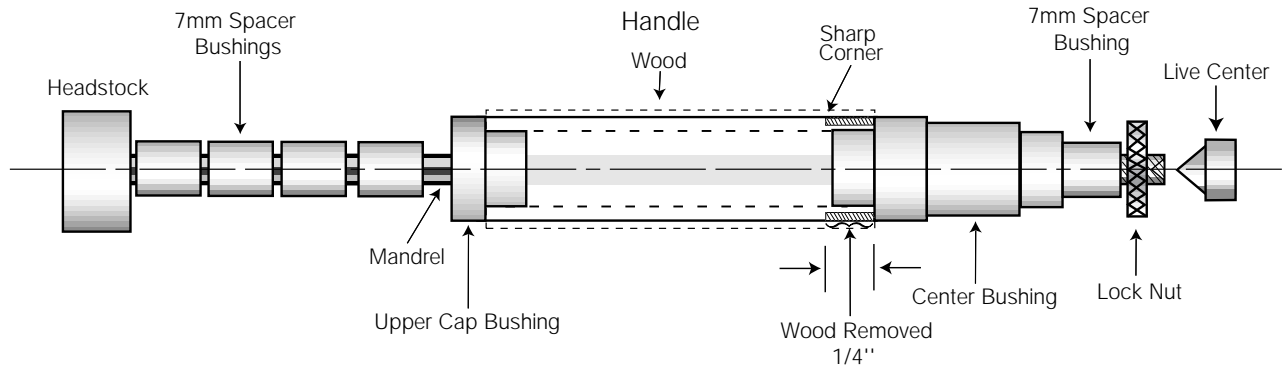

Turning the Blanks

- Place the stop bushing onto the mandrel hand tight, or use 3 or 4, 7mm bushings. Place the cap bushing (wider dia.) wide end first. Then slide on the blank. Place the center bushing (wide dia. end first) on the mandrel. Adjust spaces on stop bushing. Thread on the lock nut hand tight. Bring the tail stock snug with the mandrel. (Do not overtighten, it could damage the mandrel). Slide the stop bushing (if used) toward the blank adjusting to remove spaces. Then tighten the lock nut.
- Turn the wood down, flush with the bushings using a lathe chisel and gradual higher grits of sand paper. Final sand both blanks for later finishing.
- For the next step, remove the tail stock and unscrew the lock nut. Remove the center bushing and turn it 180°, replace on the mandrel and lock as before.

Removing Wood for the Center Band by Making a Tenon

- With a pencil, mark 1/4" from the center bushing on the handle. Use a parting tool to remove the excess wood down flush to the outside diameter of the center bushing. (note that the center bushing has now been turned around 180 degrees, and there is a smaller diameter against the wood). Be careful, you must retain a sharp 90° corner at the end of the upper blank when you remove the excess wood.

- Remove the center bushing from the mandrel to test the fit of the center band on the tenon. If no rework is needed, continue.
- Finish the handle with your choice of polish and waxes. Friction polish and waxes are available from The Wooden Post.

Assembly

- To assemble the parts, use a vise or a clamping instrument with wooden jaws. Press slowly with caution, keep the parts aligned to avoid cracking the wood or scratching the gold plating.
- Press the cap nut, recessed end first, into the flat end of the handle.
- Use a drop of glue on the tenon, slide the center band (square end first) onto the handle. Press in and let dry. (Parts must be flush together with no gaps).
- Unscrew the coupling of the magnifier or letter opener and press it into the opposite end of the handle until the coupling is flush with the band.
- Thread the magnifier or letter opener back inside the coupling.
- Insert the spacer over the cap thread and screw into the cap nut.

NOTE: The threaded hole in the coupling will match the male thread on the magnifier or the letter opener blade.