

Wooden Post #'s are highlighted in yellow.

Model #PKSC-PEN TWP # 1189 Sculptured Pen Kit

Kit Features:

- 24 kt. Gold Plated with Epoxy Coating.
- Smooth Twist Operation.
- Sculptured cast design to match the Magnifier and Letter Opener Kits.
- Uses Parker® Type Ball Point Refill.
- Overall Length: 5-3/8".

Required Accessories

- 7mm Long Mandrel.
- 3 Pc. Pen Bushing Set #PKSC-BU. TWP #1192
- 8mm Drill Bit: #PKPARK-8MM TWP #1580
- 8mm Barrel Trimmer #PK-TRIM8 (optional). TWP #1588
- 2 Part Epoxy Glue or Insta-Cure (cyanoacrylate).

Diagram A - Parts Layout

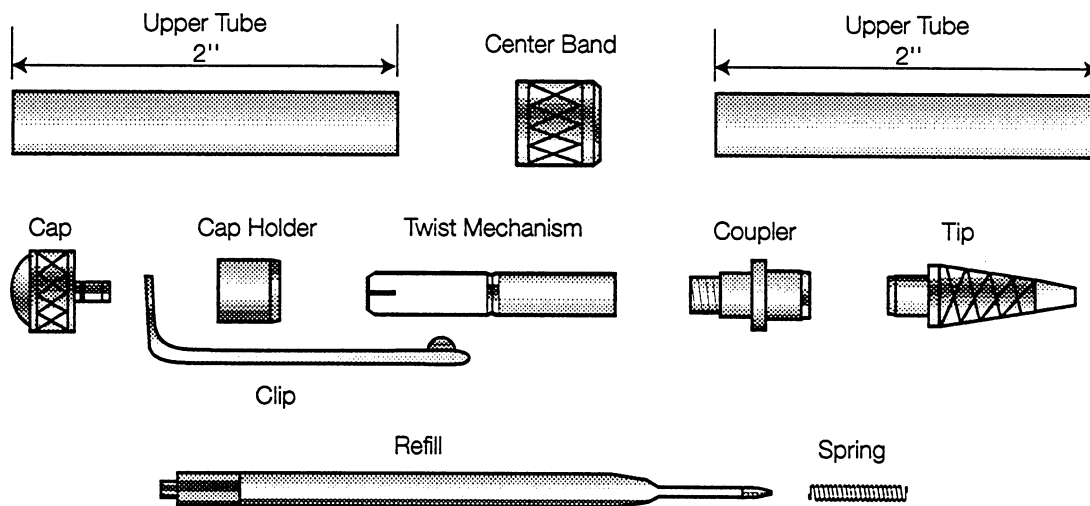

Preparing The Blank

- Cut 5/8" to 3/4" square blank to the length of the brass tube (add 1/16" for squaring off).
- Drill an 8mm center hole, lengthwise through the blank.
- Spread the glue over the tube. Insert the tube into the blank with a twisting motion to spread the glue evenly inside. Center the tube lengthwise inside the blank.
- When the glue dries, square the ends of the blank. Use an 8mm barrel trimmer or a belt/disc sander to trim the wood down flush to the end of the brass tube.

Diagram B - Turning The Blanks

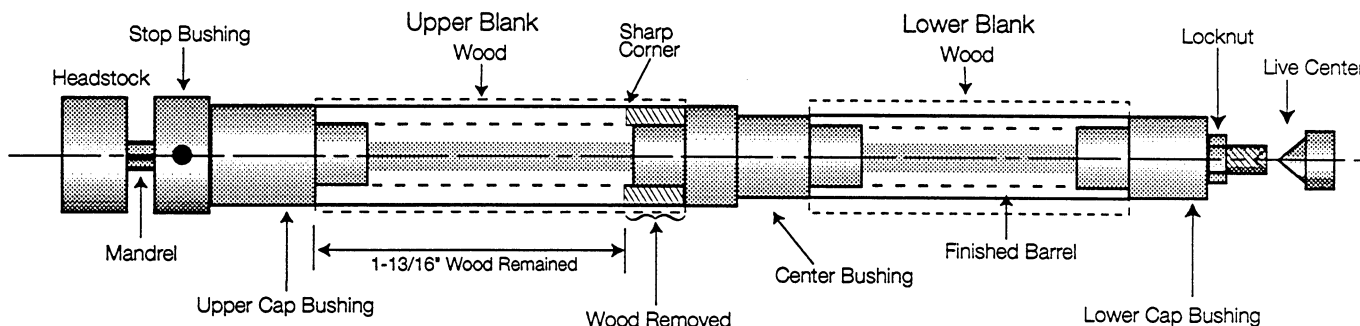

Turning The Blanks

- Place the stop bushing onto the mandrel hand tight. Next, place the longer cap bushing, wide dia. first, on the mandrel. Next, slide on the upper blank, then place the center bushing (wide dia. first) on the mandrel. Slide on the lower blank and follow with the shorter bushing. Thread on the lock nut hand tight. Bring the tail stock snug with the mandrel. (Do not overtighten, it could damage the mandrel)

Slide the stop bushing toward the blank, adjusting to remove spaces. Then tighten the set screw, and tighten the lock nut.

- Using a lathe chisel, turn the blank down flush with the bushings. Finish the blank with gradual higher grits of sand paper and your choice of polish and waxes.

Removing Wood For Center Band:

- Use a pencil to mark 1-13/16" from the long cap bushing on the upper barrel. Use a parting tool to remove the excess wood down to the brass tube. Be careful, you must retain a sharp 90° corner at the end of the upper blank when you remove the excess wood.
- Sand both blanks then finish the blanks with your choice of polish and waxes.

Assembly

- Line up finished parts according to Diagram A.

Upper Barrel

- Insert the cap stud through the hole in the clip.
- Press the cap stud into the chamfered side of the cap holder, and press it all the way in, creating the cap assembly.
- Press the cap assembly into the wood covered end of the barrel.
- Press the center band, square end first, over the bare brass tube flush against the wood.

Lower Barrel

- Press tip end into either end of the barrel.

- Press the coupler into the opposite end of the barrel with the threaded end out.
- Insert the refill and spring into the barrel. Screw the brass end of the twist mechanism into the coupler to the end.

Final Assembly

- Engage and push the entire twist mechanism into the upper barrel.
- The pen operates by twisting the two ends to extend or retract the refill.
- To replace the refill: Pull the ends apart and change the refill. Push back together.

Bushings - #PKSC-BU TWP #1192

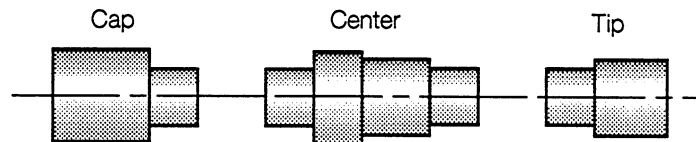

Provided for your use by - The Wooden Post, Inc. -
Pittsburg, MO 65724 Toll free (888) 595-7126